

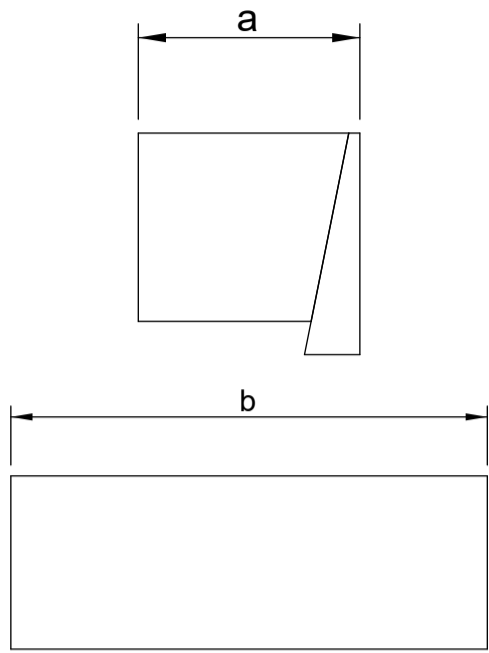

Gdm *The new
Revolution*

槽型刀盤固定刀座型錄
Static Tool holder





外徑刀上下壓板
clamping element

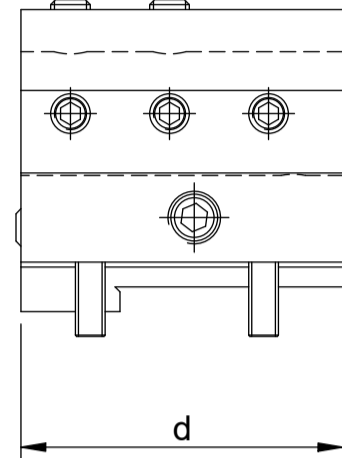
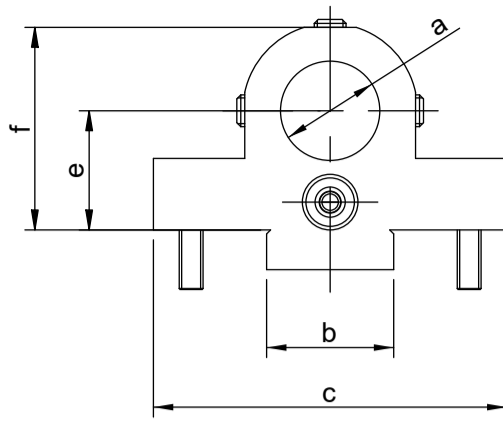

搪孔刀座
Boring bar tool holder

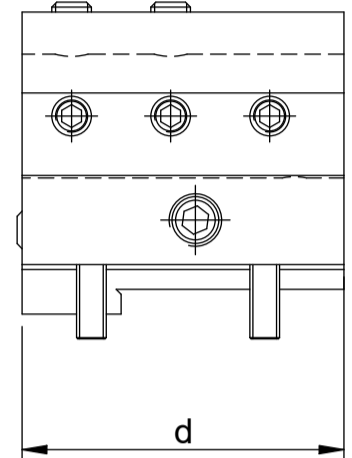
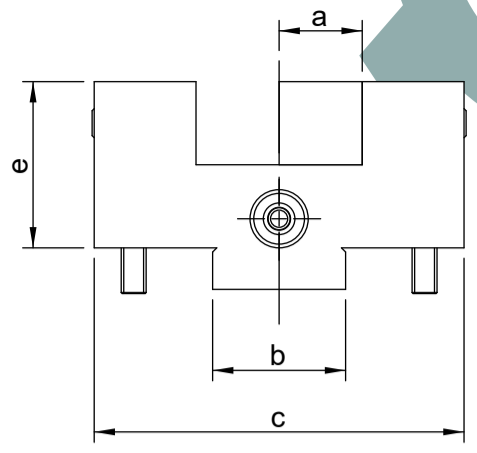

端面刀座
Facing tool holder

刀盤規格 Specs of tool disc	刀座品號 Part ID of tool holder	品名 Description of Goods	尺寸 (mm) dimensions					
			a	b	c	d	e	f
標準刀盤組/公制/Tool disc 440.212/SW220/8T/W3/25BAR/T65	508102005	搪孔刀座組/H25.065.089.02/外出水 Boring bar tool holder/coolant supply external	25	32	89	65	30	51
	508102028	搪孔刀座組/H25.065.089.02/中心出水 Boring bar tool holder/coolant supply internal	25	32	89	65	30	51
	508101017	端面刀座組/F20.065.089.02/外出水 Facing tool holder/coolant supply external	20	32	89	65	40	-
	41103001-01	上壓板/公制/P055.020.00 clamping element (upper)	20	55	-	-	-	-
	41103002-01	下壓板/公制/P055.020.01 clamping element (lower)						
標準刀盤組/公制/Tool disc 40.212/SW220/8T/W9/25BAR/T65	508102005	搪孔刀座組/H25.065.089.02/外出水 Boring bar tool holder/coolant supply external	25	32	89	65	30	51
	508102028	搪孔刀座組/H25.065.089.02/中心出水 Boring bar tool holder/coolant supply internal	25	32	89	65	30	51
	508101017	端面刀座組/F20.065.089.02/外出水 Facing tool holder/coolant supply external	20	32	89	65	40	-
	41103001-01	上壓板/公制/P055.020.00 clamping element (upper)	20	55	-	-	-	-
	41103002-01	下壓板/公制/P055.020.01 clamping element (lower)						
標準刀盤組/公制/Tool disc 440.216/SW270/8T/W3/25BAR/T85	508101018	端面刀座組/F25.085.100.3/外出水 Facing tool holder/coolant supply external	25	30	100	85	55	-
	508102038	搪孔刀座組/H32.085.100.3/外出水 Boring bar tool holder/coolant supply external	32	30	100	85	40	75
	508102037	搪孔刀座組/H32.085.100.3/中心出水 Boring bar tool holder/coolant supply internal	32	30	100	85	40	75
	508102026	搪孔刀座組/H40.085.100.3/外出水 Boring bar tool holder/coolant supply external	40	30	100	85	40	75
	508102010	搪孔刀座組/H40.085.100.3/中心出水 Boring bar tool holder/coolant supply internal	40	30	100	85	40	75
	41103010-01	上壓板/公英制共用/P070.025.00 clamping element (upper)	25	70	-	-	-	-
	41103011-01	下壓板/公制/P070.025.01 clamping element (lower)						
標準刀盤組/公制/Tool disc 440.216/SW316/12T/W9/25BAR/T80	508102009	搪孔刀座組/H40.080.084.3/外出水 Boring bar tool holder/coolant supply external)	40	30	84	80	35	70
	508102076	搪孔刀座組/H40.080.084.3/中心出水 Boring bar tool holder/coolant supply internal	40	30	84	80	35	70
	508102030	搪孔刀座/H32.080.084.3/外出水 Boring bar tool holder/coolant supply external	32	30	84	80	30	56
	508102031	搪孔刀座/H32.080.084.3/中心出水 Boring bar tool holder/coolant supply internal	32	30	84	80	30	56
	508102014	搪孔刀座組/H25.080.084.3/外出水 Boring bar tool holder/coolant supply external	25	30	84	80	30	56
	508102024	搪孔刀座組/H25.080.084.3/中心出水 Boring bar tool holder/coolant supply internal	25	30	84	80	30	56
	508101023	端面刀座組/F20.080.084.3/50BAR Facing tool holder	20	30	84	80	45	-
	41103005-01	上壓板/公制/P060.020.00 Clamping element (upper)	20	60	-	-	-	-
	41103009-01	下壓板/公英制共用/P060.020.01 Clamping element (lower)						

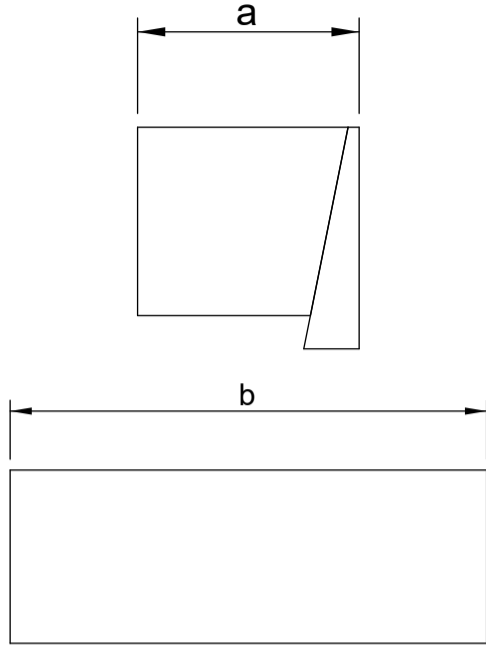

外徑刀上下壓板
clamping element

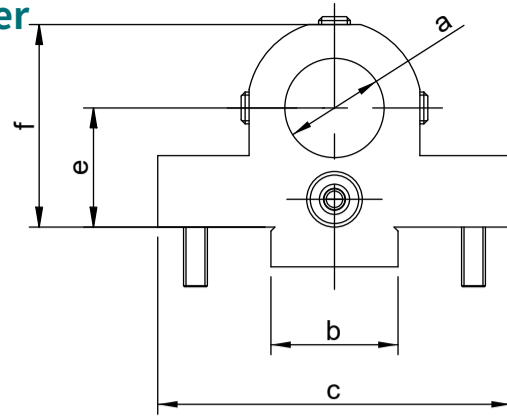

搪孔刀座
Boring bar tool holder

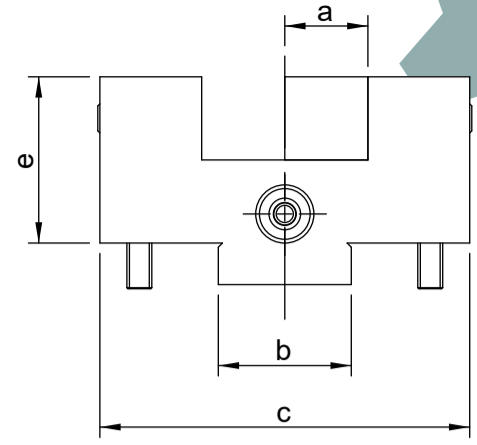
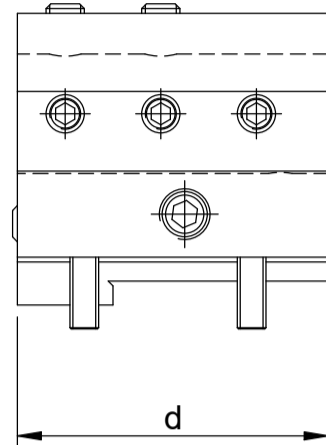

端面刀座
Facing tool holder

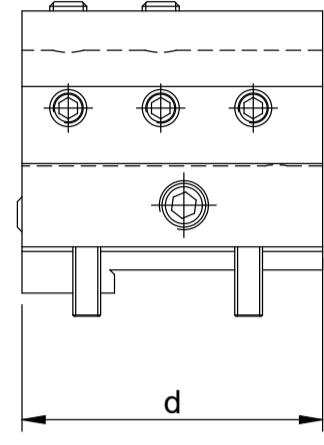

刀盤規格 Specs of tool disc	刀座品號 Part ID of tool holder	品名 Description of Goods	尺寸 (mm) dimensions					
			a	b	c	d	e	f
標準刀盤組/公制/Tool disc 440.216/SW330/8T/W3/25BAR/T85	508102010	搪孔刀座組/H40.085.100.3/中心出水 Boring bar tool holder/coolant supply internal	40	30	100	85	40	75
	508102026	搪孔刀座組/H40.085.100.3/外出水 Boring bar tool holder/coolant supply external	40	30	100	85	40	75
	508102037	搪孔刀座組/H32.085.100.3/中心出水 Boring bar tool holder/coolant supply internal	32	30	100	85	40	75
	508102038	搪孔刀座組/H32.085.100.3/外出水 Boring bar tool holder/coolant supply external	32	30	100	85	40	75
	508101018	端面刀座組/F25.085.100.3/外出水 Facing tool holder/coolant supply external	25	30	100	85	55	-
	41103010-01	上壓板/公英制共用/P070.025.00 clamping unit (upper)	25	70	-	-	-	-
	41103011-01	下壓板/公制/P070.025.01 clamping unit (lower)						
標準刀盤組/公制 /440.220/SW380/12T/W3/25BAR/T85	508102010	搪孔刀座組/H40.085.100.3/中心出水 Boring bar tool holder/coolant supply internal	40	30	100	85	40	75
	508102026	搪孔刀座組/H40.085.100.3/外出水 Boring bar tool holder/coolant supply external	40	30	100	85	40	75
	508101018	端面刀座組/F25.085.100.3/外出水 Facing tool holder/coolant supply external	25	30	100	85	55	-
	41103010-01	上壓板/公英制共用/P070.025.00 clamping element (upper)	25	70	-	-	-	-
	41103011-01	下壓板/公制/P070.025.01 clamping element (lower)						
標準刀盤組/公制/Tool disc 440.220/SW410/12T/W3/25BAR/T85	508102010	搪孔刀座組/H40.085.100.3/中心出水 Boring bar tool holder/coolant supply internal	40	30	100	85	40	75
	508102026	搪孔刀座組/H40.085.100.3/外出水 Boring bar tool holder/coolant supply external	40	30	100	85	40	75
	508101018	端面刀座組/F25.085.100.3/外出水 Facing tool holder/coolant supply external	25	30	100	85	55	-
	41103010-01	上壓板/公英制共用/P070.025.00 clamping element (upper)	25	70	-	-	-	-
	41103011-01	下壓板/公制/P070.025.01 clamping element (lower)						
標準刀盤組/公制/Tool disc 440.225/SW420/12T/W3/25BAR/T85	508102060	搪孔刀座組/H40.085.100.5/外出水 Boring bar tool holder/coolant supply external	40	30	100	85	35	65
	508102062	搪孔刀座組/H40.085.100.5/中心出水 Boring bar tool holder/coolant supply internal	40	30	100	85	35	65
	508101024	端面刀座組/F25.085.100.5/雙外出水 Facing tool holder/coolant supply external	25	30	100	85	55	-
	41103034	上壓板/公制/P090.025.00 clamping element (upper)	25	90	-	-	-	-
	41103014-01	下壓板/公制/P090.025.01 Clamping element (lower)						
標準刀盤組/公制/Tool disc 440.232/SW520/12T/W3/25BAR/T108	508102003	搪孔刀座組/H50.118.118.3/中心出水 Boring bar tool holder/coolant supply internal	50	21.9	118	118	40	84
	508102029	搪孔刀座組/H50.118.118.01/外出水 Boring bar tool holder/coolant supply external	50	21.9	118	118	40	84
	508101015	端面刀座組/F32.113.118.3/外出水 Facing tool holder/coolant supply external	32	21.9	118	113	60	-
	41103015-01	上壓板/公制/P110.032.00 Clamping element (upper)	32	110	-	-	-	-
	41103016-01	下壓板/公制/P110.032.01 Clamping element (lower)						