



Gpm *The new
Revolution*

BMT 刀座型錄
BMT Tool holder



固定刀座

Static Tool holder

搪孔刀座
Boring bar Tool holder

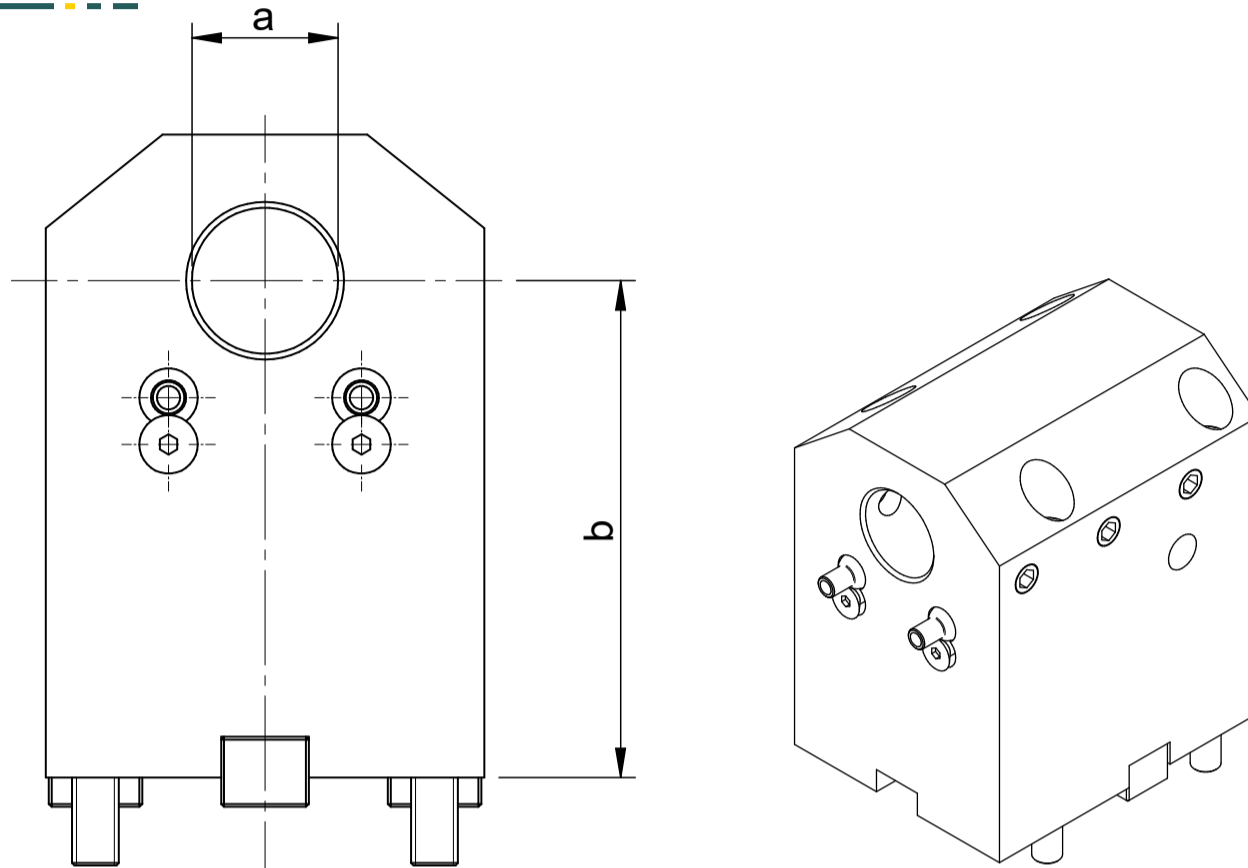

Type	Specifications	a Ø(mm)	b NH(mm)
BMT45	搪孔刀座組 Boring bar tool holder /BMT45/B25-65	25	65
	搪孔刀座組 Boring bar tool holder /BMT45/B32-65	32	65
	搪孔刀座組 Boring bar tool holder /BMT45/B40-65	40	65
	搪孔刀座組 Boring bar tool holder /BMT45/B25-85	25	85
BMT55	搪孔刀座組 Boring bar tool holder /BMT55/B25-70	25	70
	搪孔刀座組 Boring bar tool holder /BMT55/B32-60	32	60
	搪孔刀座組 Boring bar tool holder /BMT55/B32-70	32	70
	搪孔刀座組 Boring bar tool holder /BMT55/B32-85	32	85
	搪孔刀座組 Boring bar tool holder /BMT55/B32-110	32	110
	搪孔刀座組 Boring bar tool holder /BMT55/B40-60	40	60
	搪孔刀座組 Boring bar tool holder /BMT55/B40-70	40	70
	搪孔刀座組 Boring bar tool holder /BMT55/B40-85	40	85
	搪孔刀座組 Boring bar tool holder /BMT55/B40-90	40	90
	BMT65	搪孔刀座組 Boring bar tool holder /BMT65/B40-72	40
搪孔刀座組 Boring bar tool holder /BMT65/B40-100		40	100
搪孔刀座組 Boring bar tool holder /BMT65/B40-115		40	115
搪孔刀座組 Boring bar tool holder /BMT65/B50-100		50	100
BMT75	搪孔刀座組 Boring bar tool holder /BMT75/B50-60	50	60
	搪孔刀座組 Boring bar tool holder /BMT75/B50-90	50	90
	搪孔刀座組 Boring bar tool holder /BMT75/B50-100	50	100
	搪孔刀座組 Boring bar tool holder /BMT75/B50-110	50	110
	搪孔刀座組 Boring bar tool holder /BMT75/B50-120	50	120
	搪孔刀座組 Boring bar tool holder /BMT75/B50-125	50	125
	搪孔刀座組 Boring bar tool holder /BMT75/B60-90	60	90
	搪孔刀座組 Boring bar tool holder /BMT75/B80-120	80	120
BMT85	搪孔刀座組 Boring bar tool holder /BMT85/B100-110	100	110

※ 上述皆為標配：中心出水

※ The above are standard : coolant supply internal

固定刀座

Static Tool holder

端面刀座 Facing Tool holder

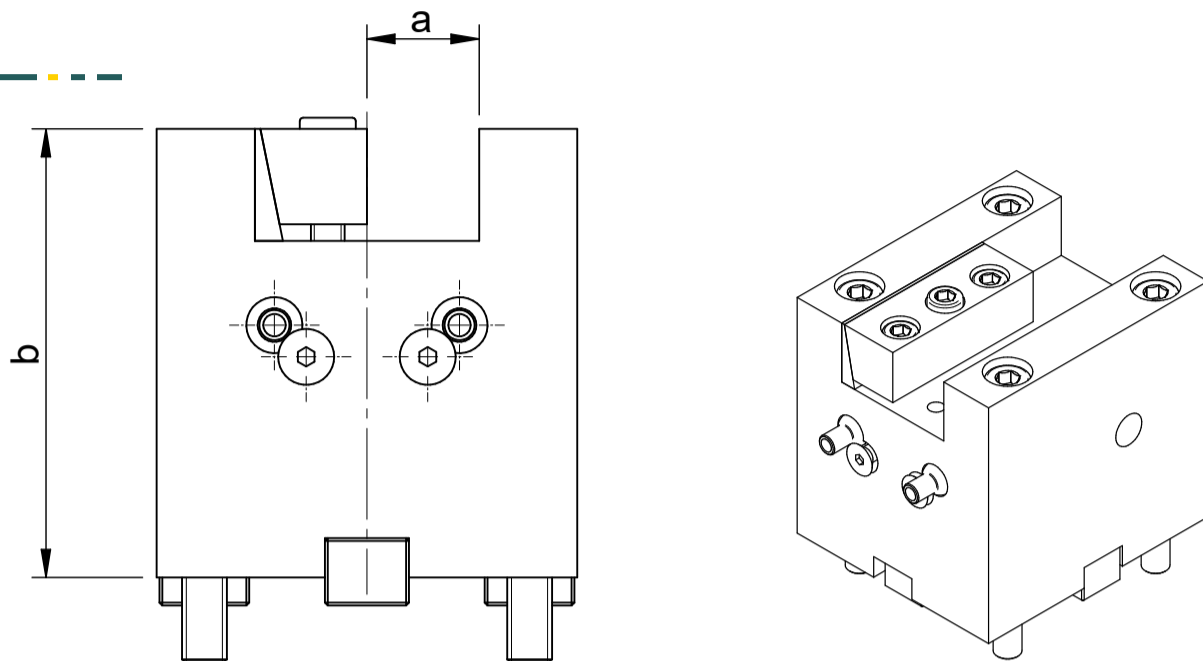

Type	Specifications	a Shank(mm)	b Height(mm)
BMT45	端面刀座組Facing Tool holder /BMT45/F20-80	25	80
BMT55	端面刀座組Facing Tool holder /BMT55/F25-60	25	60
	端面刀座組Facing Tool holder /BMT55/F25-110	25	110
BMT65	端面刀座組Facing Tool holder /BMT65/F25-82.5	25	82.5
	端面刀座組Facing Tool holder /BMT65/F25-120	25	120
BMT75	端面刀座組Facing Tool holder /BMT75/F25-122	25	122
	端面刀座組Facing Tool holder /BMT75/F32-122	32	122
	端面刀座組Facing Tool holder /BMT75/F32-90	32	90
BMT85	端面刀座組Facing Tool holder /BMT85/F40-110	40	110

外徑刀座 Turning Tool holder

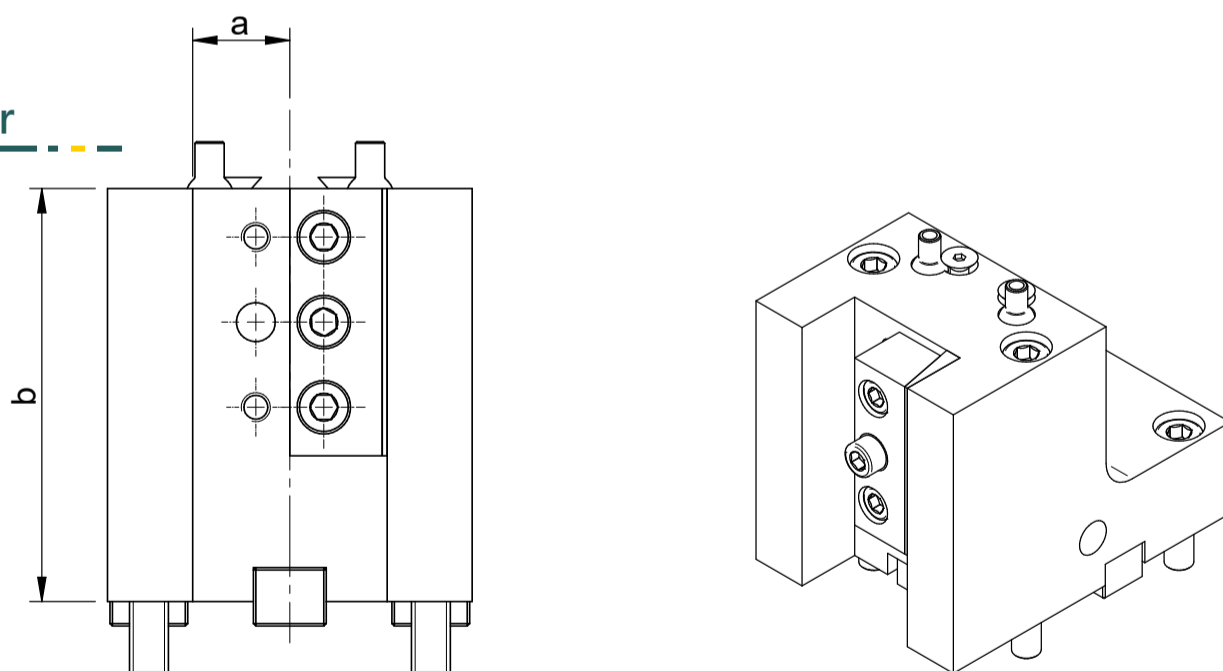

Type	Specifications	a Shank(mm)	b Height(mm)
BMT45	外徑刀座組Turning Tool holder /BMT45/C20-60	20	60
	外徑刀座組Turning Tool holder /BMT45/C20-85	20	85
	外徑刀座組Turning Tool holder /BMT45/C25-40	25	40
BMT55	外徑刀座組Turning Tool holder /BMT55/C20-80	20	80
	外徑刀座組Turning Tool holder /BMT55/C25-60	25	60
	外徑刀座組Turning Tool holder /BMT55/C25-80	25	80
BMT65	外徑刀座組Turning Tool holder /BMT65/C25-75	25	75
BMT75	外徑刀座組Turning Tool holder /BMT75/C25-100	25	100
	外徑刀座組Turning Tool holder /BMT75/C32-100	32	100
BMT85	外徑刀座組Turning Tool holder /BMT85/C40-90	40	90

固定刀座

Static Tool holder

Turning Tool holder

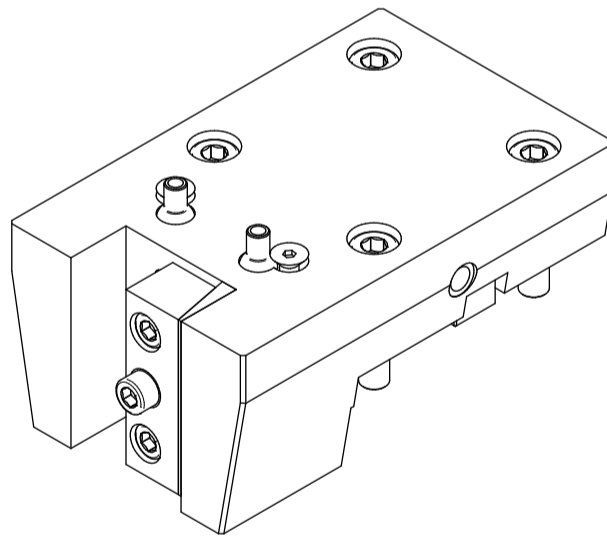
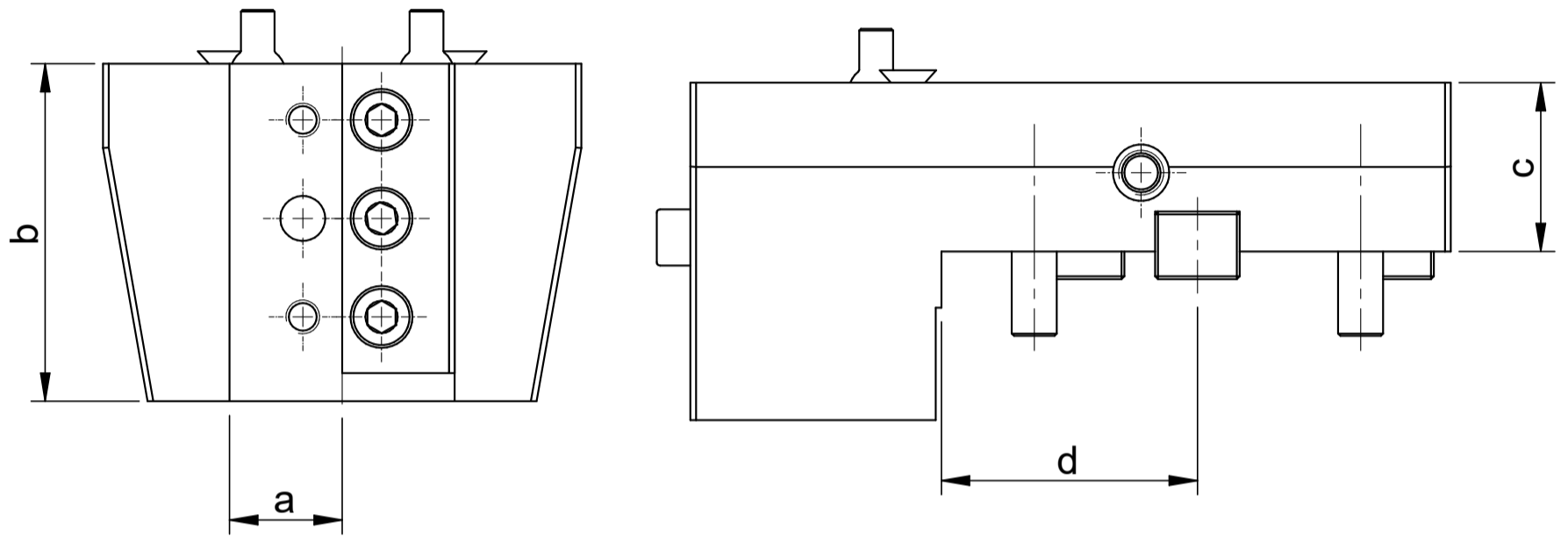

Type	Specifications	a Shank(mm)	b Height(mm)	c Height(mm)	d Length(mm)
BMT45	外徑刀座組Turning Tool holder/BMT45/C20-30	20	60	30	45
BMT55	外徑刀座組Turning Tool holder/BMT55/C20-30	20	80	30	50.2
	外徑刀座組Turning Tool holder/BMT55/C25-30	25	80	30	50.2
BMT65	外徑刀座組Turning Tool holder/BMT65/C25-30	25	72	30	55.5
BMT75	外徑刀座組Turning Tool holder/BMT75/C32-40	32	90	40	56
	外徑刀座組Turning Tool holder/BMT75/C32-70	32	115	70	56.5

動力刀座

Driven Tool holder

(Doosan 1809)

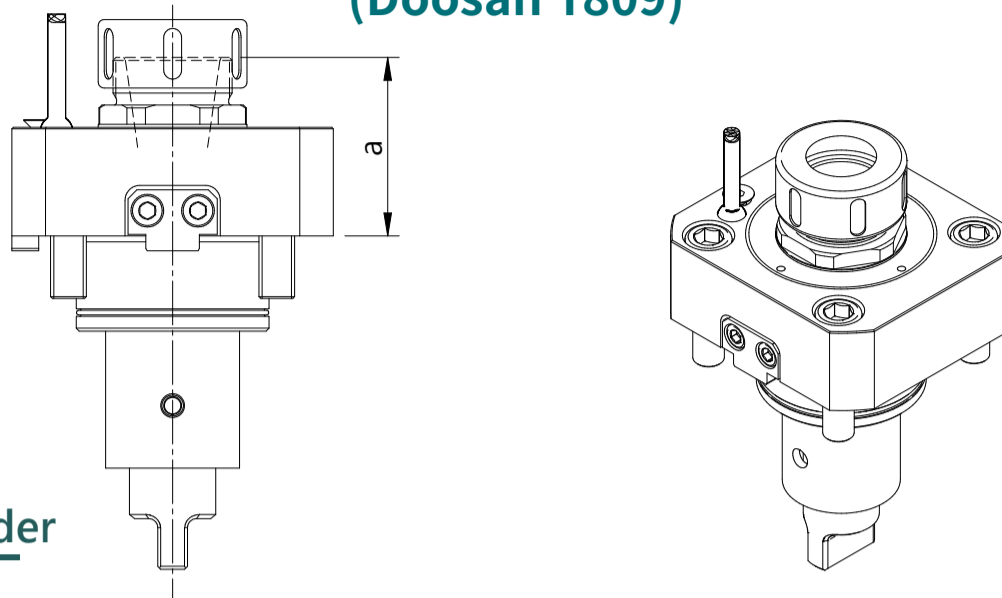

Straight driven Tool holder

Type	ER	a NL(mm)	coolant supply	speed (rpm)	gear ratio i=n1:n2	Specs
BMT45	25	51	ext. 5~80BAR	6000	1	BMT45-1809-25
	25	57	int. 5~80BAR	6000	1	BMT45-1809-25
BMT55	25	51	ext. 5~80BAR	6000	1	BMT55-1809-25
	25	51	int. 5~80BAR	6000	1	BMT55-1809-25
BMT65	32	60	ext. 5~80BAR	6000	1	BMT65-1809-32
	32	60	int. 5~80BAR	6000	1	BMT65-1809-32
BMT75	40	64.5	ext. 5~80BAR	5500	1	BMT75-1809-40
	40	64.5	int. 5~80BAR	5500	1	BMT75-1809-40
BMT85	50	102	ext. 5~80BAR	5000	1	BMT85-1809-50

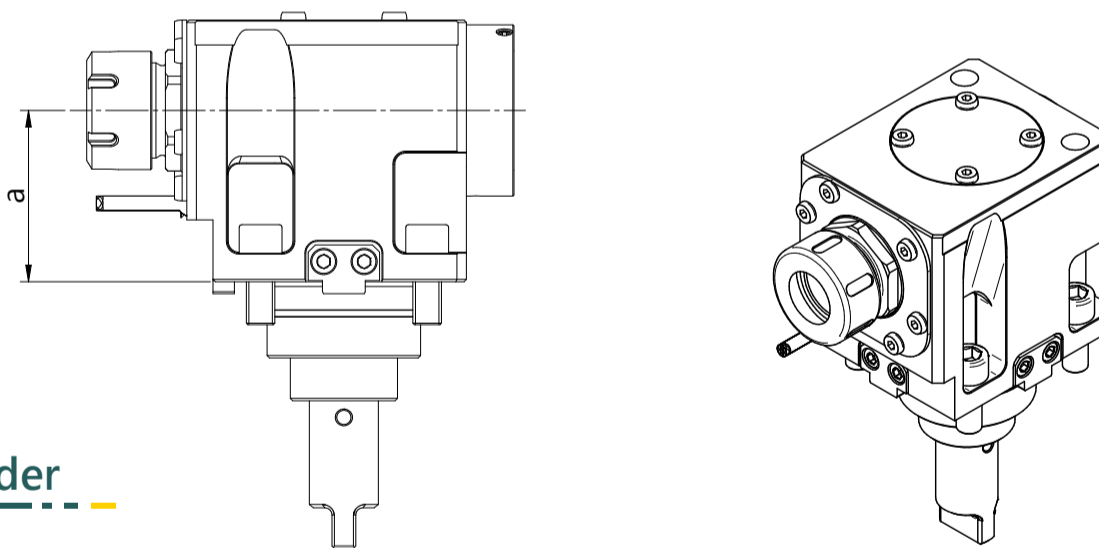

90° 動力刀座
90° driven Tool holder

Type	ER	a NH(mm)	coolant supply	speed (rpm)	gear ratio i=n1:n2	Specs
BMT45	25	65	ext. 5~80BAR	6000	1	BMT45-1809-25-65
	25	65	ext. 5~80BAR	6000	1	BMT45-1809-25-65
	25	85	int. 5~80BAR	6000	1	BMT45-1809-25-85
BMT55	25	70	ext. 5~80BAR	6000	1	BMT55-1809-25-70
	25	70	ext. 5~80BAR	6000	1	BMT55-1809-25-70
	25	85	int. 5~80BAR	6000	1	BMT55-1809-25-85
BMT65	32	72	ext. 5~80BAR	6000	1	BMT65-1809-32-72
	32	72	int. 5~80BAR	6000	1	BMT65-1809-32-72
BMT75	40	60	ext. 5~80BAR	5500	1	BMT75-1809-40-60
	40	60	int. 5~80BAR	5500	1	BMT75-1809-40-60
BMT85	50	110	ext. 5~80BAR	5000	1	BMT85-1809-50-110